

DEWALT®

www.DEWALT.com

DW621
DW622

Figure 1

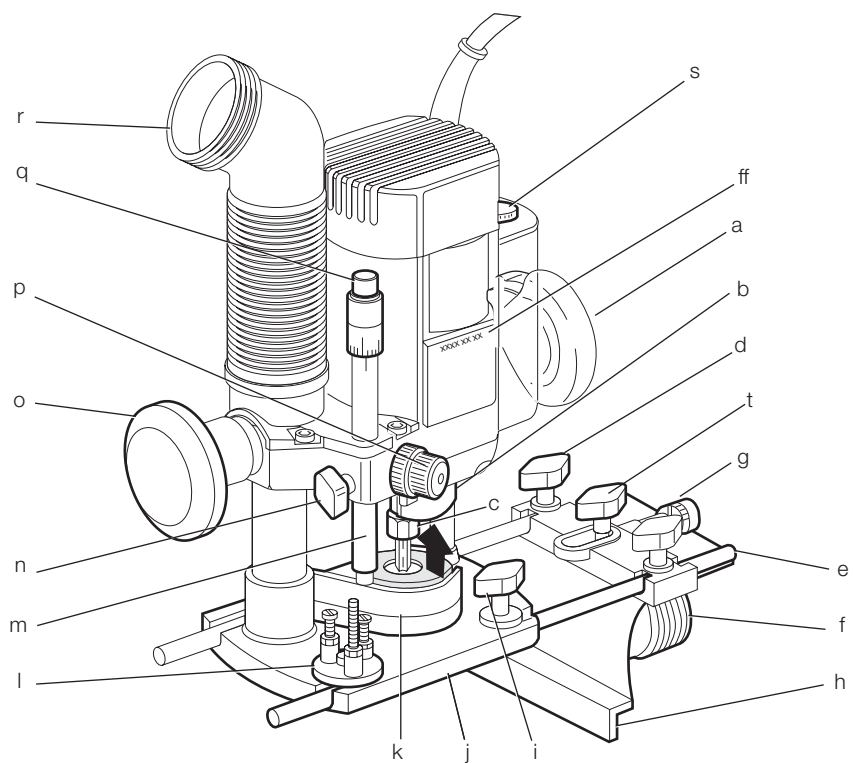

Figure 2

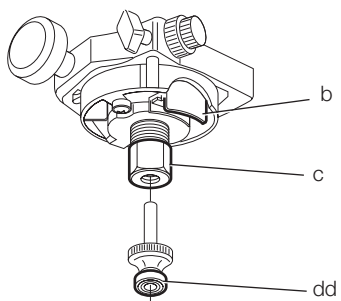

Figure 3

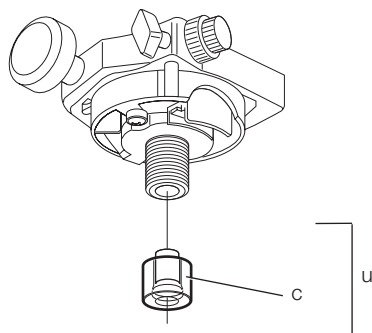

Figure 7

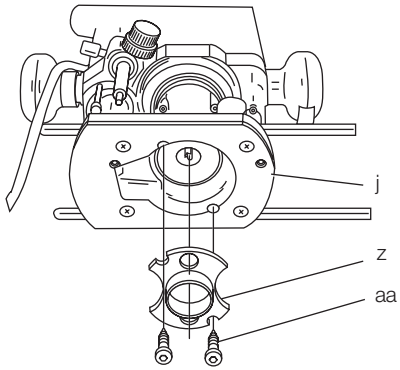

Figure 8

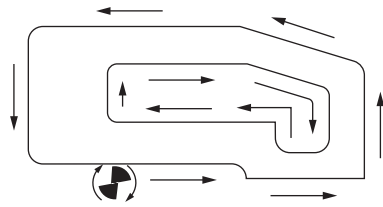

Figure 9

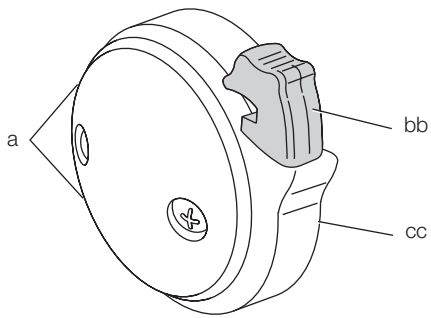

Figure 10

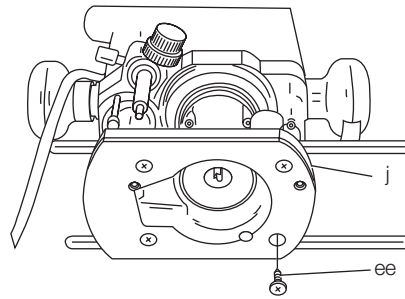
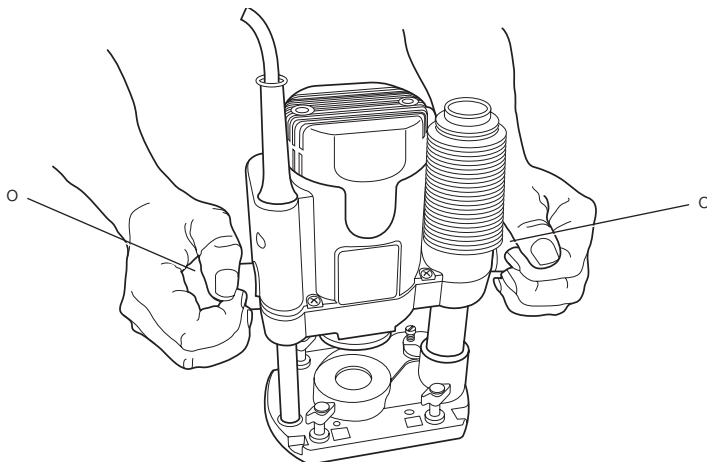

Figure 11



ROUTER

DW621, DW622

Congratulations!

You have chosen a DEWALT tool. Years of experience, thorough product development and innovation make DEWALT one of the most reliable partners for professional power tool users.

Technical Data

		DW621 XE	DW621 GB, LX, QS	DW622 GB, LX, QS
Voltage	V	230	230	230
UK & Ireland	V	–	230/115	230/115
Type		3	3	3
Power Input	W	1,100	1,100	1,400
Power output	W	620	620	620
No-load speed	min ⁻¹	8,000–24,000 infinitely variable		
Router carriage	# columns	2	2	2
Router carriage stroke	mm	55	55	55
Revolver depth stop		3-step, with graduation and fine adjustment		
Collet size		1/4", 1/2"	8 mm (QS) 1/4" (GB, LX)	12 mm (QS) 1/2" (GB, LX)
Cutters diameter, max.	mm	36	36	36
Weight	kg	3.1	3.1	3.1
Noise values and vibration values (triax vector sum) according to EN60745-2-17.				
L_{PA} (emission sound pressure level)	dB(A)	86	86	86
L_{WA} (sound power level)	dB(A)	95	95	95
K (uncertainty for the given sound level)	dB(A)	3	3	3
Vibration emission value a_{H1} =	m/s ²	3.3	3.3	3.3
Uncertainty K =	m/s ²	1.5	1.5	1.5

The vibration emission level given in this information sheet has been measured in accordance with a standardised test given in EN 60745 and may be used to compare one tool with another. It may be used for a preliminary assessment of exposure.



WARNING: The declared vibration emission level represents the main applications of the tool. However if the tool is used for different applications, with different accessories or poorly maintained, the vibration emission may differ. This may significantly increase the exposure level over the total working period.

An estimation of the level of exposure to vibration should also take into account the times when the tool is switched off or when it is running but not actually doing the job. This may significantly reduce the exposure level over the total working period.

Identify additional safety measures to protect the operator from the effects of vibration such as: maintain the tool and the accessories, keep the hands warm, organisation of work patterns.

Fuses:

Europe	230 V tools	10 Amperes, mains
U.K. & Ireland	230 V tools	13 Amperes, in plugs

Definitions: Safety Guidelines

The definitions below describe the level of severity for each signal word. Please read the manual and pay attention to these symbols.



DANGER: Indicates an imminently hazardous situation which, if not avoided, **will result in death or serious injury.**



WARNING: Indicates a potentially hazardous situation which, if not avoided, **could result in death or serious injury.**



CAUTION: Indicates a potentially hazardous situation which, if not avoided, **may result in minor or moderate injury.**

NOTICE: Indicates a practice **not related to personal injury** which, if not avoided, **may result in property damage.**



Denotes risk of electric shock.



Denotes risk of fire.

EC-Declaration of Conformity

MACHINERY DIRECTIVE



ROUTER

DW621, DW622

DEWALT declares that these products described under **Technical Data** are in compliance with: 2006/42/EC, EN60745-1:2009 +A11:2010, EN60745-2-17:2010.

These products also comply with Directive 2014/30/EU and 2011/65/EU. For more information, please contact DEWALT at the following address or refer to the back of the manual.

The undersigned is responsible for compilation of the technical file and makes this declaration on behalf of DEWALT.

Markus Rempel
Director Engineering
DEWALT, Richard-Klinger-Straße 11,
D-65510, Idstein, Germany
02.06.2016



WARNING: To reduce the risk of injury, read the instruction manual.

General Power Tool Safety Warnings



WARNING! Read all safety warnings and instructions Failure to follow the warnings and instructions may result in electric shock, fire and/or serious injury.

SAVE ALL WARNINGS AND INSTRUCTIONS FOR FUTURE REFERENCE

The term "power tool" in the warnings refers to your mains-operated (corded) power tool or battery-operated (cordless) power tool.

1) WORK AREA SAFETY

- a) **Keep work area clean and well lit.** Cluttered or dark areas invite accidents.
- b) **Do not operate power tools in explosive atmospheres, such as in the presence of flammable liquids, gases or dust.** Power tools create sparks which may ignite the dust or fumes.
- c) **Keep children and bystanders away while operating a power tool.** Distractions can cause you to lose control.

2) ELECTRICAL SAFETY

- a) **Power tool plugs must match the outlet. Never modify the plug in any way. Do not use any adapter plugs with earthed (grounded) power tools.** Unmodified plugs and matching outlets will reduce risk of electric shock.
- b) **Avoid body contact with earthed or grounded surfaces such as pipes, radiators, ranges and refrigerators.** There is an increased risk of electric shock if your body is earthed or grounded.
- c) **Do not expose power tools to rain or wet conditions.** Water entering a power tool will increase the risk of electric shock.
- d) **Do not abuse the cord. Never use the cord for carrying, pulling or unplugging the power tool. Keep cord away from heat, oil, sharp edges or moving parts.** Damaged or entangled cords increase the risk of electric shock.
- e) **When operating a power tool outdoors, use an extension cord suitable for outdoor use.** Use of a cord suitable for outdoor use reduces the risk of electric shock.
- f) **If operating a power tool in a damp location is unavoidable, use a residual current device (RCD) protected supply.** Use of an RCD reduces the risk of electric shock.

3) PERSONAL SAFETY

- a) **Stay alert, watch what you are doing and use common sense when operating a power tool. Do not use a power tool while you are tired or under the influence of drugs, alcohol or medication.** A moment of inattention while operating power tools may result in serious personal injury.
- b) **Use personal protective equipment. Always wear eye protection.** Protective equipment such as dust mask, non-skid safety shoes, hard hat, or hearing protection used for appropriate conditions will reduce personal injuries.
- c) **Prevent unintentional starting. Ensure the switch is in the off position before connecting to power source and/or battery pack, picking up or carrying the tool.** Carrying power tools with your finger on the switch or energising power tools that have the switch on invites accidents.
- d) **Remove any adjusting key or wrench before turning the power tool on.** A wrench or a key left attached to a rotating part of the power tool may result in personal injury.
- e) **Do not overreach. Keep proper footing and balance at all times.** This enables better control of the power tool in unexpected situations.
- f) **Dress properly. Do not wear loose clothing or jewellery. Keep your hair, clothing and gloves away from moving parts.** Loose clothes, jewellery or long hair can be caught in moving parts.
- g) **If devices are provided for the connection of dust extraction and collection facilities, ensure these are connected and properly used.** Use of dust collection can reduce dust-related hazards.

4) POWER TOOL USE AND CARE

- a) **Do not force the power tool. Use the correct power tool for your application.** The correct power tool will do the job better and safer at the rate for which it was designed.
- b) **Do not use the power tool if the switch does not turn it on and off.** Any power tool that cannot be controlled with the switch is dangerous and must be repaired.
- c) **Disconnect the plug from the power source and/or the battery pack from the power tool before making any adjustments, changing accessories, or storing power tools.** Such preventive safety measures reduce the risk of starting the power tool accidentally.

- d) **Store idle power tools out of the reach of children and do not allow persons unfamiliar with the power tool or these instructions to operate the power tool.** Power tools are dangerous in the hands of untrained users.
- e) **Maintain power tools. Check for misalignment or binding of moving parts, breakage of parts and any other condition that may affect the power tool's operation. If damaged, have the power tool repaired before use.** Many accidents are caused by poorly maintained power tools.
- f) **Keep cutting tools sharp and clean.** Properly maintained cutting tools with sharp cutting edges are less likely to bind and are easier to control.
- g) **Use the power tool, accessories and tool bits etc., in accordance with these instructions taking into account the working conditions and the work to be performed.** Use of the power tool for operations different from those intended could result in a hazardous situation.

5) SERVICE

- a) **Have your power tool serviced by a qualified repair person using only identical replacement parts.** This will ensure that the safety of the power tool is maintained.

Additional Safety Rules for Routers

- **Hold power tool by insulated gripping surfaces, because the cutter may contact its own cord.** Cutting a "live" wire may make exposed metal parts of the power tool "live" and shock the operator.
- **Use clamps or another practical way to secure and support the workpiece to a stable platform.** Holding the work by your hand or against the body leaves it unstable and may lead to loss of control.

Additional Safety Rules for Cutters

- Always use straight-cutters, rabbet-cutters, profile cutters, slotter cutters or grooved knives with a shank diameter of 6–8 mm which corresponds to the size of the collet in your tool.
- Always use cutters suitable for a speed of min. 30,000 min⁻¹ and marked accordingly.



WARNING: Never use cutters with a diameter exceeding the maximum diameter indicated in the technical data.

- For straight-cutters, rabbet-cutters, profile cutters, the maximum shank diameter **MUST** be 8 mm, the

maximum diameter **MUST** be 36 mm, the maximum cutting depth **MUST** be 10 mm.

- For slotter cutters, the maximum shank diameter **MUST** be 8 mm and the maximum diameter **MUST** be 25 mm.
- For grooved knives, the maximum shank diameter **MUST** be 8 mm, the maximum diameter **MUST** be 40 mm and the maximum cutting width **MUST** be 4 mm.



WARNING: We recommend the use of a residual current device with a residual current rating of 30mA or less.

Residual Risks

In spite of the application of the relevant safety regulations and the implementation of safety devices, certain residual risks cannot be avoided. These are:

- Impairment of hearing
- Risk of personal injury due flying particles.
- Risk of burns due to accessories becoming hot during operation.
- Risk of personal injury due to prolonged use.

Markings on Tool

The following pictograms are shown on the tool:



Read instruction manual before use.

DATE CODE POSITION (FIG. 1)

The Date Code (ff), which also includes the year of manufacture, is printed into the housing.

Example:

XX XX 2016

Year of Manufacture

Package Contents

The package contains:

- 1 Router
- 1 Parallel fence with fine adjustment and guiderods
- 1 Collet 1/4" (DW621-XE, DW621 GB, LX)
- 1 Collet 1/2" (DW621-XE, DW622 GB, LX)
- 1 Collet 8 mm (DW621 QS)
- 1 Collet 12 mm (DW622 QS)
- 1 Guide bush 24 mm

- 1 Wrench # 17 (DW621 GB, LX, QS)
- 1 Wrench # 22 (DW621-XE, DW622 GB, LX, QS)
- 1 Dust extraction plug
- 1 Instruction manual
- Check for damage to the tool, parts or accessories which may have occurred during transport.
- Take the time to thoroughly read and understand this manual prior to operation.

Description (fig. 1)



WARNING: Never modify the power tool or any part of it. Damage or personal injury could result.

- Lock-on/lock-off switch
- Spindle lock
- Collet nut
- Parallel fence locking bolt
- Guide rods for parallel fence
- Dust extraction outlet in parallel fence
- Fine adjuster for parallel fence
- Parallel fence
 - Locking bolt
 - Router base
 - Finger guard
 - Revolver depth stop
 - Depth stop
 - Depth stop locking bolt
 - Plunge limiter
 - Quick adjuster for depth stop
 - Fine adjuster for depth stop
 - Dust extraction adaptor
 - Speed control dial
 - End lock

INTENDED USE

Your DEWALT DW621/DW622 high-performance routers have been designed for professional heavy duty routing of wood, wood products and plastics.

DO NOT use under wet conditions or in presence of flammable liquids or gases.

These routers are professional power tools.

DO NOT let children come into contact with the tool. Supervision is required when inexperienced operators use this tool.

- **Young children and the infirm.** This appliance is not intended for use by young children or infirm persons without supervision.
- This product is not intended for use by persons (including children) suffering from diminished physical, sensory or mental abilities; lack of experience, knowledge or skills unless they are supervised by a person responsible for their safety. Children should never be left alone with this product.

Electrical Safety

The electric motor has been designed for one voltage only. Always check that the power supply corresponds to the voltage on the rating plate.



Your DEWALT tool is double insulated in accordance with EN 60745; therefore no earth wire is required.



WARNING: 115 V units have to be operated via a fail-safe isolating transformer with an earth screen between the primary and secondary winding.

If the supply cord is damaged, it must be replaced by a specially prepared cord available through the DEWALT service organisation.

Mains Plug Replacement (U.K. & Ireland Only)

If a new mains plug needs to be fitted:

- Safely dispose of the old plug.
- Connect the brown lead to the live terminal in the plug.
- Connect the blue lead to the neutral terminal.



WARNING: No connection is to be made to the earth terminal.

Follow the fitting instructions supplied with good quality plugs. Recommended fuse: 13 A.

Using an Extension Cable

If an extension cable is required, use an approved 3-core extension cable suitable for the power input of this tool (see technical data). The minimum conductor size is 1.5 mm²; the maximum length is 30 m.

When using a cable reel, always unwind the cable completely.

ASSEMBLY AND ADJUSTMENTS



WARNING: To reduce the risk of injury, turn unit off and disconnect machine from power source before

installing and removing accessories, before adjusting or changing set-ups or when making repairs. Be sure the trigger switch is in the OFF position. An accidental start-up can cause injury.

Inserting and Removing a Cutter (fig. 2)

1. Press and hold down the spindle lock (b).
2. Using the wrench supplied, loosen the collet nut (c) a few turns and insert a cutter (dd).
3. Tighten the collet nut and release the spindle lock.



WARNING: Never tighten the collet nut without a cutter in the collet.

Replacing the Collet Assembly (fig. 3)

Your router is supplied with a 1/4", 1/2", 8 mm, or 12 mm collet fitted to the tool. The collet and the collet nut are inseparable.

1. Loosen the collet nut (c) completely.
2. Remove the collet assembly (u).
3. Fit a new assembly and tighten the collet nut (c).

Setting the Electronic Speed Control Dial (fig. 1)

The speed is infinitely variable from 8,000 to 24,000 min⁻¹ using the electronic speed control dial (s) for uniform cutting results in all types of wood, plastics and in aluminium.

Turn the electronic speed control dial to the required level.

Generally, use the low setting for large diameter cutters and the high setting for small diameter cutters. The correct setting, however, is a matter of experience.

- | | |
|-----|--------------------------|
| 1 = | 8,000 min ⁻¹ |
| 2 = | 9,500 min ⁻¹ |
| 3 = | 11,500 min ⁻¹ |
| 4 = | 16,000 min ⁻¹ |
| 5 = | 19,500 min ⁻¹ |
| 6 = | 22,500 min ⁻¹ |
| 7 = | 24,000 min ⁻¹ |

Adjusting the Depth of Cut (fig. 4)

Your router is equipped with a high-precision depth adjustment system including a zero reset ring for both the quick adjuster and the fine adjuster.

QUICK ADJUSTMENT USING THE GRADUATION WITH ZERO RESET RING

1. Loosen the depth stop locking bolt (n).
2. Unlock the plunge limiter (o) by turning it counterclockwise.
3. Lower the router carriage until the cutter is in contact with the workpiece.
4. Tighten the plunge limiter (o).
5. Set the quick adjuster (p) to zero using the ring (v). The depth stop (m) must be in contact with the revolver depth stop (l).
6. Adjust the depth of cut using the quick adjuster (p) and the corresponding graduation. The adjusted depth of cut is indicated by the arrows (w).
7. Tighten the depth stop locking bolt (n).

TRIPLE DEPTH ADJUSTMENT USING THE REVOLVER DEPTH STOP

The revolver depth stop (l) can be used to set three different depths. This is particularly useful for deep cuts, performed in steps.

- Place a depth template between the depth stop (m) and the revolver depth stop (l) to adjust the exact cutting depth.
- If required, set all three screws.

FINE ADJUSTMENT

When not using a depth template, or if the depth of cut needs readjustment, it is recommended to use the fine adjuster (q).

1. Adjust the depth of cut as described above.
2. Set the fine adjuster to zero using the ring (x).
3. Rotate the fine adjuster (q) to the required position: one turn corresponds to approximately 1 mm and 1 mark to 0.1 mm.

Depth Adjustment with Router

INSTALLED IN INVERTED POSITION (FIG. 4)

1. Remove the depth stop (m) and replace it with the depth stop (DE6956) available as an option.
2. Connect the threaded rod of the depth stop (m) to the revolver depth stop (l).
3. Set the depth of cut using the adjuster on the depth stop (m).



WARNING: For installing the router in inverted position, refer to the relevant instruction manual on the stationary tool.

Fitting the Parallel Fence (fig. 1, 5)

1. Fit the guide rods (e) to the router base (j).
2. Tighten the locking bolts (i).
3. Slide the parallel fence (h) over the rods.
4. Tighten the locking bolts (d) temporarily.
5. Remove the dust extraction adaptor (r) and close the outlet using the dust extraction plug (y) supplied with the tool.

Adjusting the Parallel Fence (fig. 6)

1. Draw a cutting line on the material.
2. Lower the router carriage until the cutter is in contact with the workpiece.
3. Tighten the plunge limiter (o).
4. Position the router on the cutting line.
5. Slide the parallel fence (h) against the workpiece and tighten the locking bolts (d).
6. Adjust the parallel fence (h) using the fine adjuster (g). The outer cutting edge of the cutter must coincide with the cutting line.
7. Firmly tighten the end lock (t).

Fitting a Guide Bush (fig. 7)

Together with a template, guide bushes play a valuable part in cutting and shaping to a pattern.

- Fit the guide bush (z) to the router base (j) using the screws (aa) as shown.



Connecting a Dust Extractor (fig. 1, 5)

Connect a dust extractor hose to the dust extraction adaptor (r) in the router carriage column or to the dust extraction outlet in the parallel fence (f).

Prior to Operation

1. Check that the cutter is correctly installed in the collet.
2. Select the optimal speed using the electronic speed control dial.
3. Set the cutting depth.
4. Connect a dust extractor.
5. Make sure the plunge limiter is always locked before switching on.

OPERATION

Instructions for Use



WARNING: Always observe the safety instructions and applicable regulations.



WARNING: To reduce the risk of serious personal injury, turn tool off and disconnect tool from power source before making any adjustments or removing/installing attachments or accessories.



WARNING: Always move your router as indicated in figure 8 (outer edges/inner edges).

Proper Hand Position (fig. 11)



WARNING: To reduce the risk of serious personal injury, **ALWAYS** use proper hand position as shown.



WARNING: To reduce the risk of serious personal injury, **ALWAYS** hold securely in anticipation of a sudden reaction.

Proper hand position requires one hand on either plunge limiter (o).

Switching On and Off (fig. 9)

The lock-on/lock-off switch (a) is located in the handle on the right-hand side. The router is normally locked in the off position.

1. Switching on: press and hold down the switch (bb) to unlock the tool and subsequently squeeze the trigger (cc).
2. For continuous operation, press the switch (bb) again.
3. Switching off: squeeze the trigger (cc) again.



WARNING: Loosen the plunge limiter and allow the router carriage to regain its rest position before switching off.

Using the Guide Bushes (fig. 7)

1. Secure the template to the workpiece using end clamps.
2. Select and install an appropriate guide bush (z).
3. Subtract the diameter of the cutter from the outside diameter of the guide bush and divide by 2. This is the difference between template and workpiece.



WARNING: If the workpiece is not thick enough, place it on a piece of waste wood.

Guiding Off a Batten

Where an edge guide cannot be used, it is also possible to guide the router along a batten clamped across the workpiece (with an overhang at both ends).

Freehand Routing

Your router can also be used without any sort of guide, e.g. for signwriting or creative work.



WARNING: Make shallow cuts only! Use cutters with a max. diameter of 8 mm.

Routing with Pilot Cutters (fig. 2)

Where a parallel guide or guide bush are inappropriate, it is possible to use pilot cutters (dd) for cutting shaped edges.

Consult your dealer for further information on the appropriate accessories.

These include collets (6–12 mm), a depth stop for use in inverted position, finger jointing tools for dovetail and finger jointing jigs, dowel jointing templates, guide bushes (17–40 mm) and guide rails in various lengths.

MAINTENANCE

Your DEWALT power tool has been designed to operate over a long period of time with a minimum of maintenance. Continuous satisfactory operation depends upon proper tool care and regular cleaning.



WARNING: To reduce the risk of injury, turn unit off and disconnect machine from power source before installing and removing accessories, before adjusting or changing set-ups or when making repairs. Be sure the trigger switch is in the OFF position. An accidental start-up can cause injury.

Cleaning the Dust Extraction Column (fig. 10)

1. Remove the dust extraction plug or adaptor.
2. Remove the four screws (ee) in the bottom of the router base (j).
3. Clean the dust extraction column.
4. Reassemble the parts in reverse order.



Lubrication

Your power tool requires no additional lubrication.



Cleaning



WARNING: Blow dirt and dust out of the main housing with dry air as often as dirt is seen collecting in and around the air vents. Wear approved eye protection and approved dust mask when performing this procedure.



WARNING: Never use solvents or other harsh chemicals for cleaning the non-metallic parts of the tool. These chemicals may weaken the materials used in these parts. Use a cloth dampened only with water and mild soap. Never let any liquid get inside the tool; never immerse any part of the tool into a liquid.

Optional Accessories



WARNING: Since accessories, other than those offered by DEWALT, have not been tested with this product, use of such accessories with this tool could be hazardous. To reduce the risk of injury, only DEWALT, recommended accessories should be used with this product.

Consult your dealer for further information on the appropriate accessories.

Protecting the Environment



Separate collection. This product must not be disposed of with normal household waste.

Should you find one day that your DEWALT product needs replacement, or if it is of no further use to you, do not dispose of it with household waste. Make this product available for separate collection.



Separate collection of used products and packaging allows materials to be recycled and used again. Re-use of recycled materials helps prevent environmental pollution and reduces the demand for raw materials.

Local regulations may provide for separate collection of electrical products from the household, at municipal waste sites or by the retailer when you purchase a new product.

DEWALT provides a facility for the collection and recycling of DEWALT products once they have reached the end of their working life. To take advantage of this service please return your product to any authorised repair agent who will collect them on our behalf.

You can check the location of your nearest authorised repair agent by contacting your local DEWALT office at the address indicated in this manual. Alternatively, a list of authorised DEWALT repair agents and full details of our after-sales service and contacts are available on the Internet at: www.2helpU.com.

Belgique et Luxembourg België en Luxemburg	DEWALT - Belgium BVBA Egide Walschaertsstraat 16 2800 Mechelen	Tel: NL 32 15 47 37 63 Tel: FR 32 15 47 37 64 Fax: 32 15 47 37 99	www.dewalt.be enduser.BE@SBDinc.com
Danmark	DEWALT Roskildevej 22 2620 Albertslund	Tel: 70 20 15 10 Fax: 70 22 49 10	www.dewalt.dk kundeservice.dk@sbdinc.com
Deutschland	DEWALT Richard Klinger Str. 11 65510 Idstein	Tel: 06126-21-1 Fax: 06126-21-2770	www.dewalt.de infodwge@sbdinc.com
Ελλάς	DEWALT (Ελλάς) A.E. ΕΔΡΑ-ΓΡΑΦΕΙΑ : Σπράβωνος 7 & Λ. Βουλιαγμένης, Γλυφάδα 166 74, Αθήνα SERVICE : Ημέρος Τόπος 2 (Χάνι Αδάμ) – 193 00 Ασπρόπυργος	Τηλ: 00302108981616 Φαξ: 00302108983570	www.dewalt.gr Greece.Service@sbdinc.com
España	DEWALT Ibérica, S.C.A. Parc de Negocios "Mas Blau" Edificio Muntadas, c/Bergadà, 1, Of. A6 08820 El Prat de Llobregat (Barcelona)	Tel: 934 797 400 Fax: 934 797 419	www.dewalt.es respuesta.postventa@sbdinc.com
France	DEWALT 5, allée des Hêtres BP 30084, 69579 Limonest Cedex	Tel: 04 72 20 39 20 Fax: 04 72 20 39 00	www.dewalt.fr scufr@sbdinc.com
Schweiz Suisse Svizzera	DEWALT In der Luberzen 42 8902 Urdorf	Tel: 044 - 755 60 70 Fax: 044 - 730 70 67	www.dewalt.ch service@rofoag.ch
Ireland	DEWALT Calpe House Rock Hill Black Rock, Co. Dublin	Tel: 00353-2781800 Fax: 00353-2781811	www.dewalt.ie
Italia	DEWALT via Energypark 20871 Vimercate (MB), IT	Tel: 800-014353 39 039 9590200 Fax: 39 039 9590313	www.dewalt.it
Nederlands	DEWALT Netherlands BV Holtum Noordweg 35 6121 RE BORN, Postbus 83, 6120 AB BORN	Tel: 31 164 283 063 Fax: 31 164 283 200	www.dewalt.nl
Norge	DEWALT Postboks 4613, Nydalen 0405 Oslo	Tel: 45 25 13 00 Fax: 45 25 08 00	www.dewalt.no kundeservice.no@sbdinc.com
Österreich	DEWALT Werkzeug Vertriebsges m.b.H Oberlaaerstrasse 248, A-1230 Wien	Tel: 01 - 66116 - 0 Fax: 01 - 66116 - 614	www.dewalt.at service.austria@sbdinc.com
Portugal	DEWALT Limited, SARL Centro de Escritórios de Sintra Avenida Almirante Gago Coutinho, 132/134, Edifício 14 2710-418 Sintra	Tel: 214 66 75 00 Fax: 214 66 75 80	www.dewalt.pt resposta.posvenda@sbdinc.com
Suomi	DEWALT PL 47 00521 Helsinki	Puh: 010 400 4333 Faksi: 0800 411 340	www.dewalt.fi asiakaspalvelu.fi@sbdinc.com
Sverige	DEWALT Box 94 431 22 Mölndal	Tel: 031 68 61 60 Fax: 031 68 60 08	www.dewalt.se kundservice.se@sbdinc.com
Türkiye	KALE Hırdavat ve Makina A.Ş. Defterdar Mah. Savaklar Cad. No:15 Edimekapı / Eyüp / İSTANBUL 34050 TÜRKİYE	Tel: 0212 533 52 55 Faks: 0212 533 10 05	www.dewalt.com.tr
United Kingdom	DEWALT, 210 Bath Road; Slough, Berks SL1 3YD	Tel: 01753-567055 Fax: 01753-572112	www.dewalt.co.uk emeaservice@sbdinc.com
Australia	DEWALT 82 Taryn Drive, Epping VIC 3076 Australia	Tel: Aust 1800 338 002 Tel: NZ 0800 339 258	www.dewalt.com.au www.dewalt.co.nz
Middle East Africa	DEWALT P.O. Box - 17164, Jebel Ali Free Zone (South), Dubai, UAE	Tel: 971 4 812 7400 Fax: 971 4 2822765	www.dewalt.ae Service.MEA@sbdinc.com